

VX186-260QDM2

The Marathon Series is our high pressure line of pumps. You'll find Marathon pumps in many applications in agriculture, industry and municipalities. The Marathon is a two-stage pump which splits the pressure between chambers. This allows the pump to handle much higher pressures than any traditional rotary lobe pump.

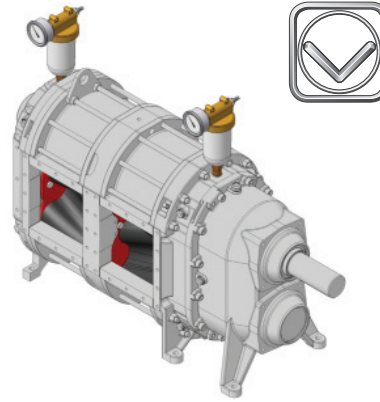

VOGELSANG

HIFLO POSITIVE DISPLACEMENT ROTARY LOBE PUMPS

Run Dry Without Damage: Vogelsang pumps are warranted against damage from run dry for a period up to 30 minutes.

Complete Wet-End Rebuilds Inline: Change rotors, mechanical seals, lip seals, wear plates, and adjust housing segments with ease.

100% Pulsation Free Operation: Vogelsang HiFlo Rotors provide pulsation free operation through the entire range of pumping.

Maximum Mechanical Seal Life: Vogelsang pumps use a pressurized oil canister to maintain pressure inside a buffer chamber between the wetend and gear box. This pressure reduces the wear on the mechanical seals and help keep your pump at optimum performance.

Self Priming to 25' (Wet): With suction lifts to 25', Vogelsang pumps excel at the toughest suction lift applications.

Compact Size Reduces Expense: Small footprints equate to reduced construction and fabrication expense.

Unlimited Drive Options: V-Belt drives, Geared Motors with reducers, Close coupled hydraulic motors, air or submersible, Power Take Off. Vogelsang pumps offer unlimited drive options.

Low Noise Operation: Just 78db at 3 feet.

Excellent for Shear Sensitive Material: Our gentle pumping action coupled with 100% pulsation free operation makes Vogelsang the pump of choice for all your shear sensitive material pumping needs.

High Pressure: The two stage design allows the pump to operate under higher pressure than a single stage pump. Marathon pumps can handle up to 232psi.

MECHANICAL SPECIFICATIONS: STANDARD & OPTIONAL

Materials:

Bearing Housing: Gray Cast Iron (230-260 Brinell)

Front Cover: Gray Cast Iron (230-260 Brinell)

Front & Rear Wear Plate Options: Hardox (700 Brinell),
Optional: Tungsten Carbide, Stainless Steel.

Pump Shaft: Carbon Steel (ASTM A470)

Shaft Sleeve: Stellite Coated Stainless Steel.

Housing Segment Options: Gray Cast Iron (750 Brinell),
Optional: Tungsten Carbide, Stainless Steel.

Mechanical Seal Options: Component Seal, Duronite or Silicon Carbide. Block Ring Cartridge Seal, Duronite (standard in new pumps) or Silicon Carbide.

Rotor Core: Gray Cast Iron

Rotor Coating Options: SBR, NBR (standard in new pumps), SewageLine®, Viton, Werobust®, Steel, Stainless Steel.

Mechanical Specifications:

Connections: Suction, 8" Discharge, 8"

Weight: 842lbs.

Rotor Options: HiFlo 4-wing Lobes

Mounting & Drive Options: Inline Gear Motor & PTO.

Housing Segment Options: Standard or Dynamic

Warranty, Testing & Quality Assurance:

Warranty: Municipal, 2 years, 100% parts and labor, including wear. Industrial & Agricultural, 1 year, manufacturer's defects.

Testing: Each pump is factory tested at the customers specified duty point at a suitable range of flow and pressure conditions in accordance with Hydraulic Institute Standards.

ISO 9001:2008 Certification: Vogelsang is a fully certified for the manufacture and repair of industrial pumping equipment.

VX186-260QDM2



PERFORMANCE SPECIFICATIONS

Series & Model	Capacity		Displacement		Max Solids		Flange Size		Max Pressure		Max. Speed
	gpm	m ³ /h	gal/100rev	l/100rev	in	mm	in	mm	QD: psi	bar	rpm 1/min
VX186-260	130-640	30-145	133.0	503	2.5	61	8	250	232	16	600

PERFORMANCE CURVES

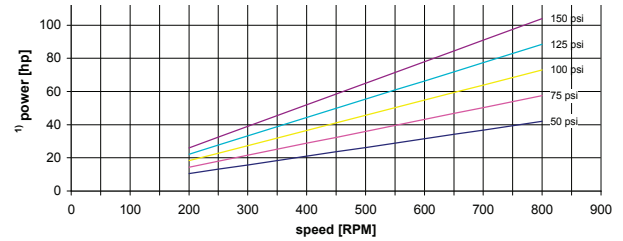
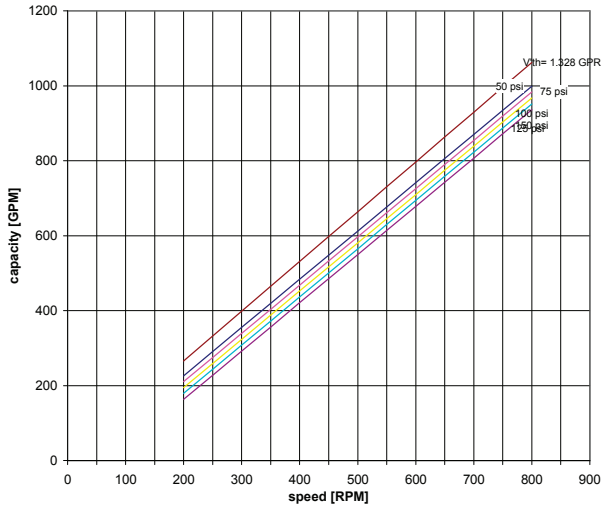

Values based upon water 70°F
¹⁾ required driving power at the pump shaft

DIMENSIONAL DRAWING

All dimensions in inches
 except shaft diameter

